



**Maha Bodhi School**  
**2019 Preliminary Examination**  
**Primary 6**  
**Mathematics**  
**Paper 1**  
**(Booklet A)**

Name : \_\_\_\_\_ (      )

Class : Primary 6 \_\_\_\_\_

Date : 27 August 2019

Total duration for Booklets A and B: 1 hour

---

**INSTRUCTIONS TO CANDIDATES:**

1. Write your Index No. in the boxes at the top right hand corner.
2. Do not turn over this page until you are told to do so.
3. Follow all instructions carefully.
4. Answer all questions.
5. Shade your answers in the Optical Answer Sheet (OAS) provided.
6. The use of calculators is **NOT** allowed.



Questions 1 to 10 carry 1 mark each. Questions 11 to 15 carry 2 marks each.  
For each question, four options are given. One of them is the correct answer.  
Make your choice (1, 2, 3 or 4) and shade your answer on the Optical Answer Sheet.  
(20 marks)

---

1. In which one of the following numbers does the digit 6 have the smallest value?

- (1) 76 859
- (2) 68 597
- (3) 597 684
- (4) 498 765

2. A tailor had 5 m of cloth. He used  $\frac{3}{8}$  of it. How much cloth had he left?

- (1)  $4\frac{5}{8}$  m
- (2)  $4\frac{3}{8}$  m
- (3)  $3\frac{1}{8}$  m
- (4)  $1\frac{7}{8}$  m

3. The length of a double-decker bus in Singapore is about \_\_\_\_\_.

- (1) 11 cm
- (2) 11 m
- (3) 110 cm
- (4) 110 m

4. Study the straight lines on the protractor below.  
Which two angles are equal?

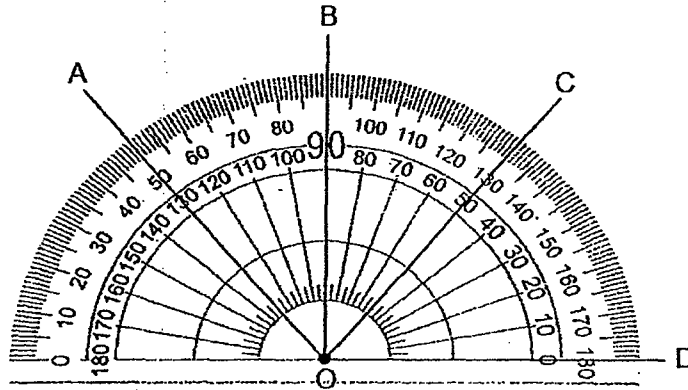

- (1)  $\angle AOC = \angle BOD$   
 (2)  $\angle AOB = \angle BOC$   
 (3)  $\angle BOC = \angle COD$   
 (4)  $\angle AOB = \angle COD$
5. Find the average of the following numbers.

10	18	26	30
----	----	----	----

- (1) 18  
 (2) 21  
 (3) 26  
 (4) 28
6. A machine packs 25 apples into a box in 1 minute. At the same rate, how many apples can be packed in 1 hour 40 minutes?
- (1) 1000  
 (2) 1500  
 (3) 2500  
 (4) 3500

7. A string was used to form Square X. The string was then used to form Figure Y with three straight sides and one curved side.

Square X has the same perimeter as Figure Y with  $AB = BC = CD = 10$  cm.

Find the length of the curved side AD.

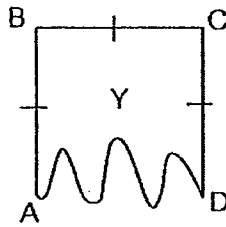
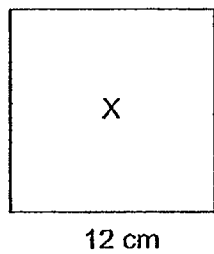

- (1) 10 cm  
 (2) 12 cm  
 (3) 18 cm  
 (4) 30 cm
8. In the diagram below, O is the centre of the circle and RQ is its diameter. RPQ is a triangle and P, Q and R are points on the circumference of the circle.  $\angle QOP = 92^\circ$ , find  $\angle ORP$ .

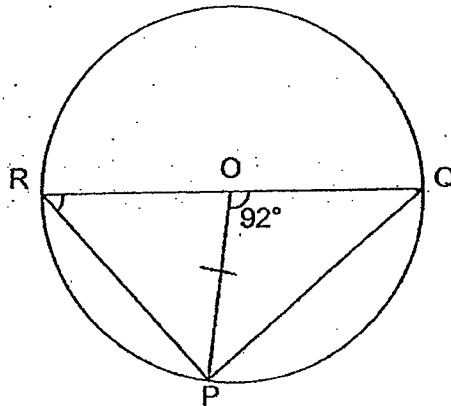

- (1)  $41^\circ$   
 (2)  $44^\circ$   
 (3)  $46^\circ$   
 (4)  $88^\circ$

9. The ticketing office at a cinema opens at 10 a.m.  
The line graph below shows the number of unsold tickets at the ticketing office after three hours.

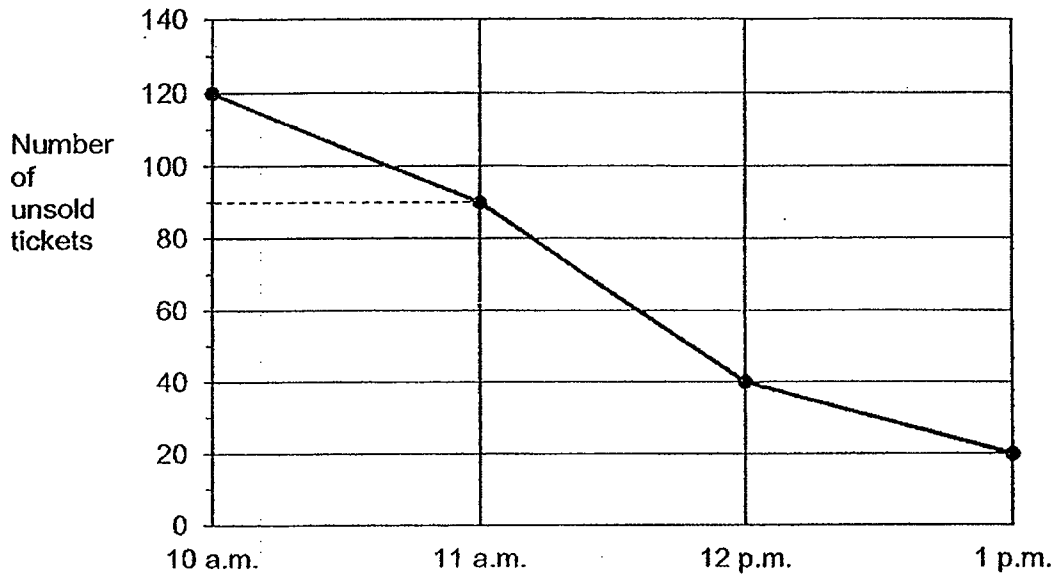

How many tickets were sold in the first hour?

- (1) 120  
(2) 90  
(3) 30  
(4) 20
10. At 11.00 a.m., a car left Town X for Town Y travelling at a speed of 80 km/h. At the same time, another car left Town Y for Town X travelling at a speed of 100 km/h. They did not change their speeds throughout. The distance between the two towns was 540 km. At what time did the cars pass each other?
- (1) 1 p.m.  
(2) 2 p.m.  
(3) 3 p.m.  
(4) 4 p.m.

11. What is the mass of Box X?

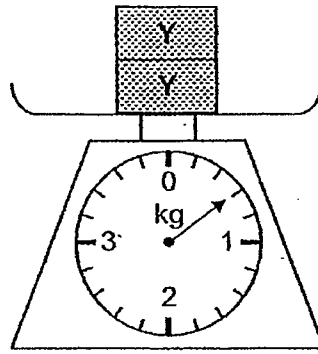
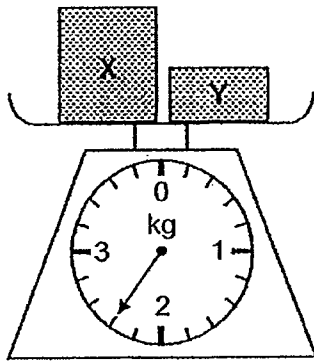

- (1) 0.3 kg  
(2) 1.8 kg  
(3) 1.9 kg  
(4) 2.1 kg
12. Plank A is 1.5 m longer than Plank B.  
Plank A is 60 cm longer than Plank C. The total length of the three planks is 12.6 m.  
Find the length of Plank B.
- (1) 3.4 m  
(2) 3.5 m  
(3) 4.3 m  
(4) 4.9 m
13. 25% of the books in a library are Malay books. 40% of the remainder are Chinese books. The rest are English books. What percentage of the books are English books?
- (1) 30%  
(2) 35%  
(3) 45%  
(4) 55%

14. Which one of the following can be the net of the solid shown below?

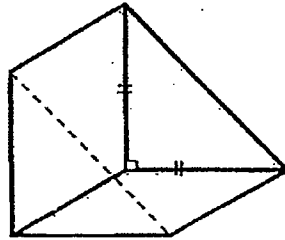

(1)

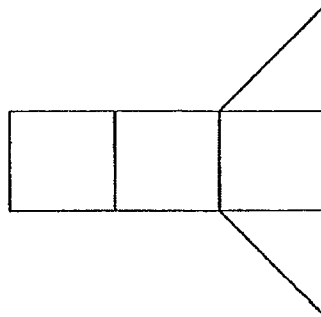

(2)

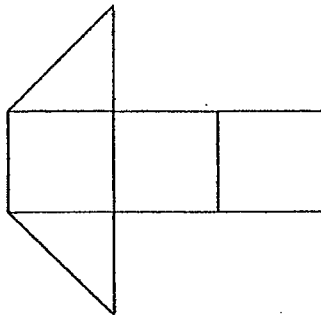

(3)

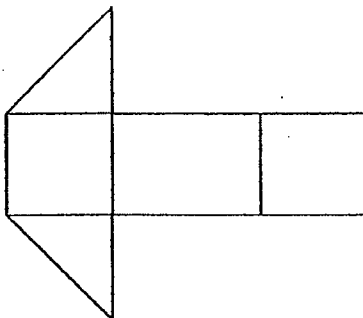

(4)

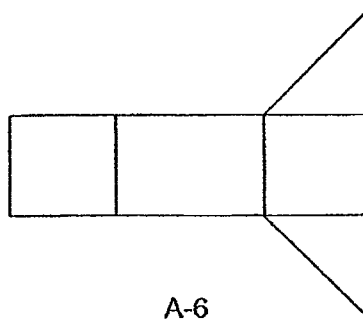

A-6



15. In the diagram below, ABCD is a parallelogram and PQRS is a rhombus.  $PB = BN$ ,  $\angle APS = 40^\circ$  and  $\angle PQR = 86^\circ$ . Find  $\angle ADC$ .

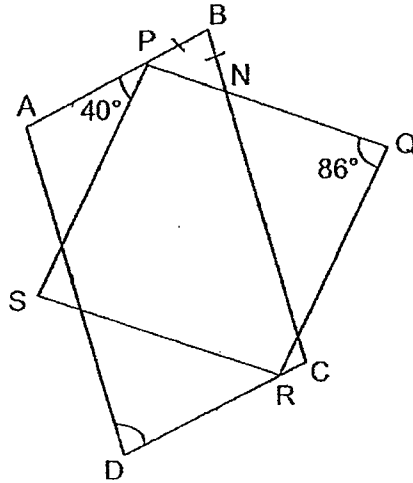

- (1)  $72^\circ$
- (2)  $88^\circ$
- (3)  $92^\circ$
- (4)  $94^\circ$





Maha Bodhi School  
2019 Preliminary Examination  
Primary 6  
Mathematics  
Paper 1  
(Booklet B)

Name : \_\_\_\_\_ (      )

Marks:

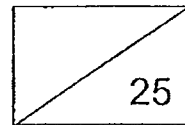

Class : Primary 6 \_\_\_\_\_

Date : 27 August 2019

Total Duration for Booklets A and B: 1 hour

---

**INSTRUCTIONS TO CANDIDATES:**

1. Write your Index No. in the boxes at the top right hand corner.
2. Do not turn over this page until you are told to do so.
3. Follow all instructions carefully.
4. Answer all questions.
5. Write all your answers in this booklet.
6. The use of calculators is **NOT** allowed.



Questions 16 to 20 carry 1 mark each. Write your answers in the spaces provided.  
For questions which require units, give your answers in the units stated. (5 marks)

---

16. Write 17 hundreds in numerals.

Ans: \_\_\_\_\_

17. The rectangle shown below is made up of 30 identical squares.  
What fraction of the rectangle is shaded? Leave your answer in the simplest form.

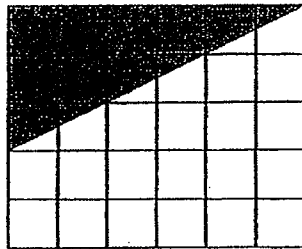

Ans: \_\_\_\_\_

18. A solid cuboid has a square base of side 5 cm. It has a volume of  $300 \text{ cm}^3$ .  
What is its height?

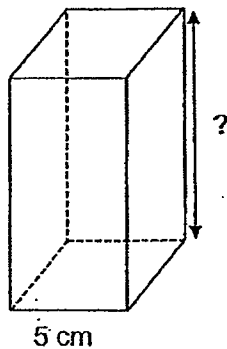

Ans: \_\_\_\_\_ cm

19. The average mass of five objects is 2.4 kg.  
The total mass of four of the objects is 10.8 kg.  
What is the mass of the fifth object?

Ans: \_\_\_\_\_ kg

20. A duck has a mass of  $3y$  kg.  
A kitten is 3 kg heavier than the duck.  
Find the total mass of the two animals in terms of  $y$ .

Ans: \_\_\_\_\_ kg

Questions 21 to 30 carry 2 marks each. Show your working clearly and write your answers in the spaces provided. For questions which require units, give your answers in the units stated. (20 marks)

21. In the number line below, what is the value of X?  
Give your answer as a decimal.

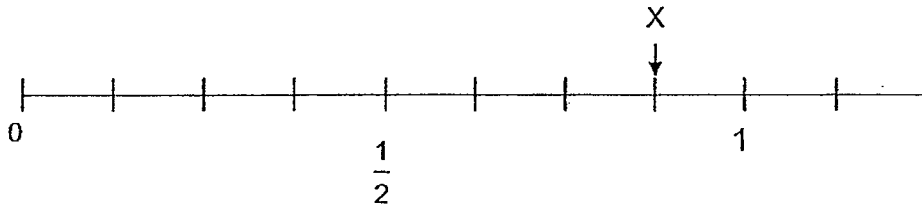

Ans: \_\_\_\_\_

22. In the figure below, PQRS is a rectangle.  
H and K are points on PQ and QR respectively such that PH = 4 cm and KR = 6 cm.  
Find the area of the shaded triangle HKR.

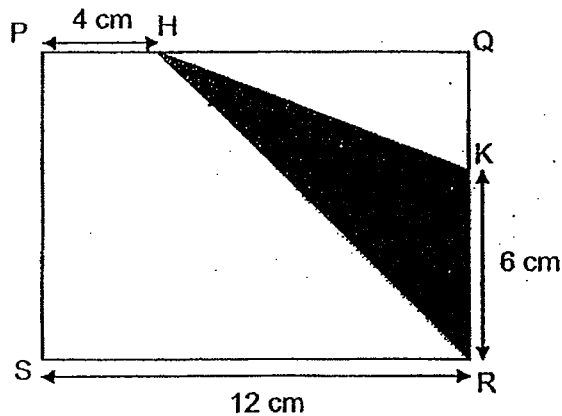

Ans: \_\_\_\_\_ cm<sup>2</sup>

23. In the grid below, draw a line parallel to AB and passing through X.

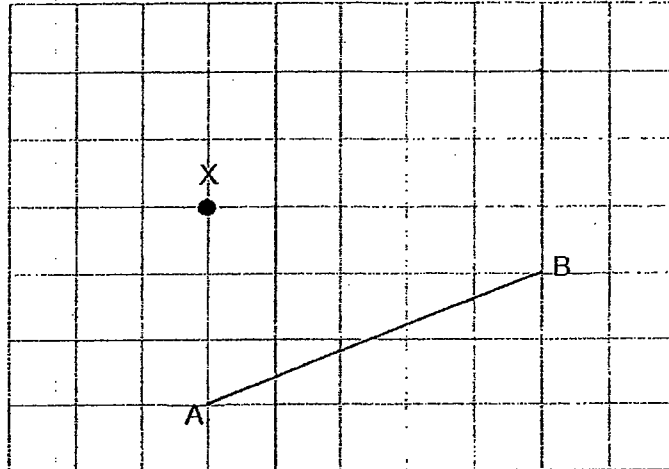

24. Apples are sold at four for \$5 and pears are sold at six for \$8.  
Kishan bought the same number of apples and pears.  
What is the least amount of money he could have spent?

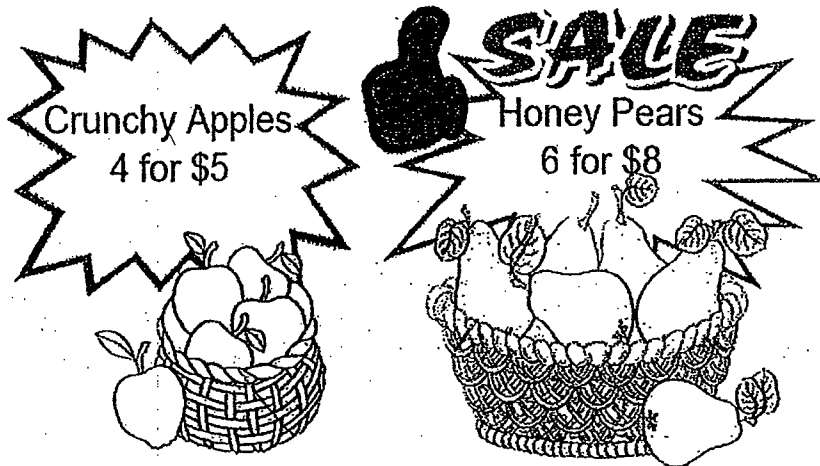

Ans: \$ \_\_\_\_\_



25. Sulaiman and Susan brought different amounts of money to school.

Sulaiman spent  $\frac{1}{2}$  of his money and Susan spent  $\frac{1}{4}$  of hers at recess.

Each of the statements below is either true, false or not possible to tell from the information given. For each statement, put a tick (✓) to indicate your answer.

Statement	True	False	Not possible to tell
Sulaiman spent more money than Susan.			
Sulaiman had a larger fraction of his money left than Susan.			

26. Haron and Raj had an equal number of stamps at first. After Haron sold 26 stamps and Raj sold 66 stamps, the ratio of the number of stamps Haron had left to the number of stamps Raj had left was 5 : 1. How many stamps did Raj have at first?

Ans: \_\_\_\_\_ stamps

27. In the diagram below,  $WXYZ$  is a parallelogram and  $ZV$  is a straight line.

Given that  $XY = YZ$  and  $\angle WXV = 130^\circ$ , find  $\angle ZWX$ .

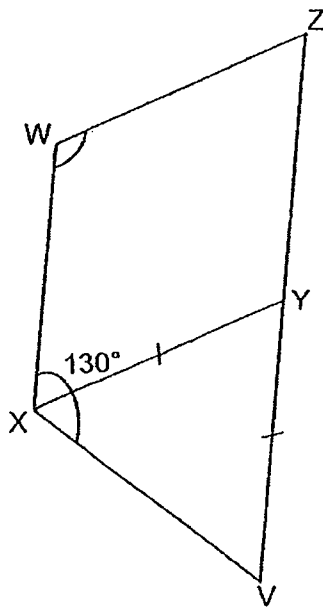

Ans: \_\_\_\_\_°

28. Pupils in a class were asked to choose a colour for their class T-shirt. Their responses are shown in the pie-chart below. AB is a straight line.

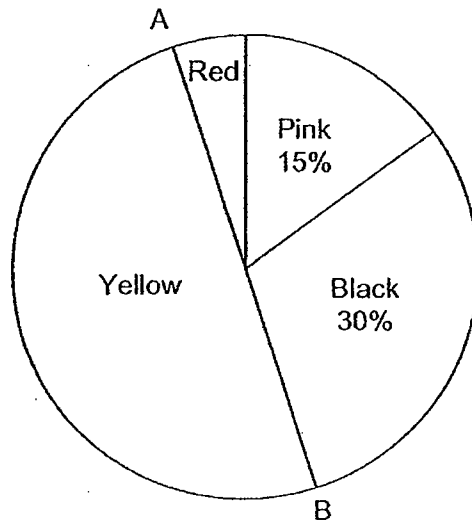

What fraction of the pupils chose red for their class T-shirt?

Ans: \_\_\_\_\_

29. Mrs Tan has  $(2n + 16)$  m of ribbon. She gave away 13 m. Then she cut the remaining ribbon into 3 equal pieces. What is the length of each piece of ribbon?

Ans: \_\_\_\_\_ m

30. There are some identical cubes in a box as shown below. How many more cubes are needed to fill up the box?

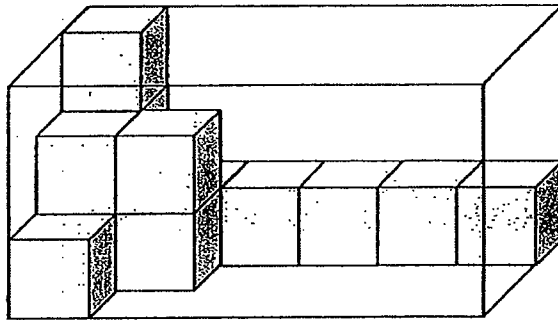

Ans: \_\_\_\_\_



**Maha Bodhi School**  
**2019 Preliminary Examination**  
**Primary 6**  
**Mathematics**  
**Paper 2**

Name : \_\_\_\_\_ (    )

Class : Primary 6 \_\_\_\_\_

Date : 27 August 2019

Duration: 1 h 30 min

---

**INSTRUCTIONS TO CANDIDATES:**

1. Write your Index No. in the boxes at the top right hand corner.
2. Do not turn over this page until you are told to do so.
3. Follow all instructions carefully.
4. Answer all questions.
5. Write your answers in this booklet.
6. The use of an approved calculator is expected, where appropriate.

Paper	Booklet	Marks Obtained	Max Marks
1	A		20
	B		25
2	-		55
<b>Total</b>			<b>100</b>

Parent's signature: \_\_\_\_\_

This booklet consists of 15 printed pages.



Questions 1 to 5 carry 2 marks each. Show your working clearly and write your answers in the spaces provided. For questions which require units, give your answers in the units stated. (10 marks)

1. A class of 40 pupils was asked to name their favourite food. Each pupil chose one type of food. The bar for the number of pupils who chose Mee Siam as their favourite food has not been drawn.

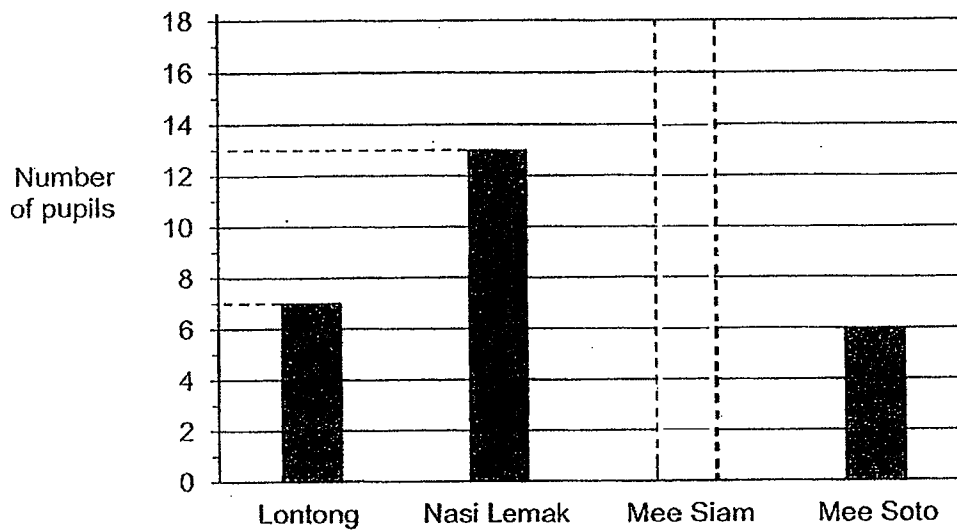

Draw the bar for the number of pupils who chose Mee Siam as their favourite food in the graph above.

2. Each figure below is made up of identical lines. The first 4 figures are shown below. Based on the pattern observed in Figures 1 to 4, how many lines are needed to form Figure 101?



Figure 1



Figure 2



Figure 3



Figure 4

Ans: \_\_\_\_\_ lines

3. Three classes collected papers for recycling. 6A collected  $4x$  kg, which is half of what 6B collected. 6B collected 5 kg more than 6C. How many kg of papers did they collect altogether?

Give your answer in terms of  $x$  in the simplest form.

Ans: \_\_\_\_\_ kg



4. The figure below shows a square of side 14 cm and 4 identical quarter circles.

Find the area of the shaded parts. Take  $\pi = \frac{22}{7}$

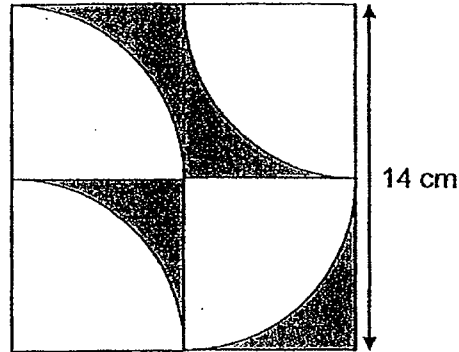

Ans: \_\_\_\_\_ cm<sup>2</sup>

5. At a school event, 15 pupils were standing in a straight line at equal distances from each other. The distance between the third and tenth pupil was 12.11 m. What was the distance between the first and last pupil?

Ans: \_\_\_\_\_ m

14

For questions 6 to 17, show your working clearly and write your answers in the spaces provided. The number of marks available is shown in brackets [ ] at the end of each question or part-question. (45 marks)

6. PQRS is a rhombus.
- (a) Using the protractor given, find  $\angle QRS$
- (b) then calculate  $\angle PQS$

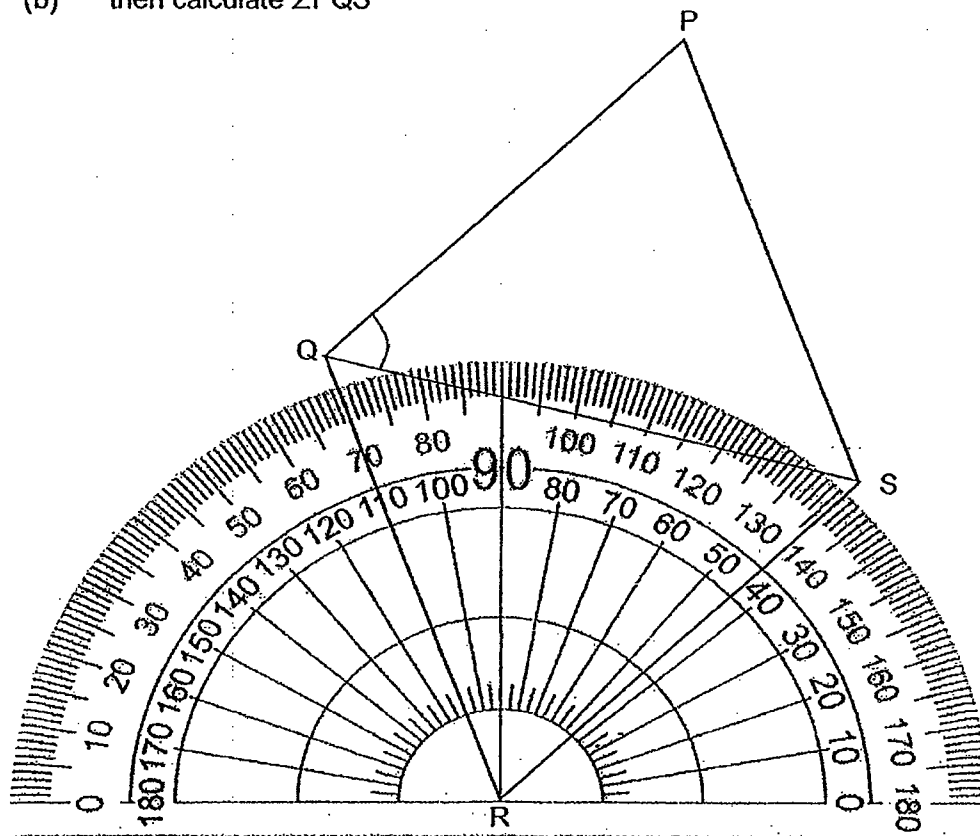

Ans: (a) \_\_\_\_\_ [1]

(b) \_\_\_\_\_ [2]

7. Some points are marked on the square grid shown in the diagram below.

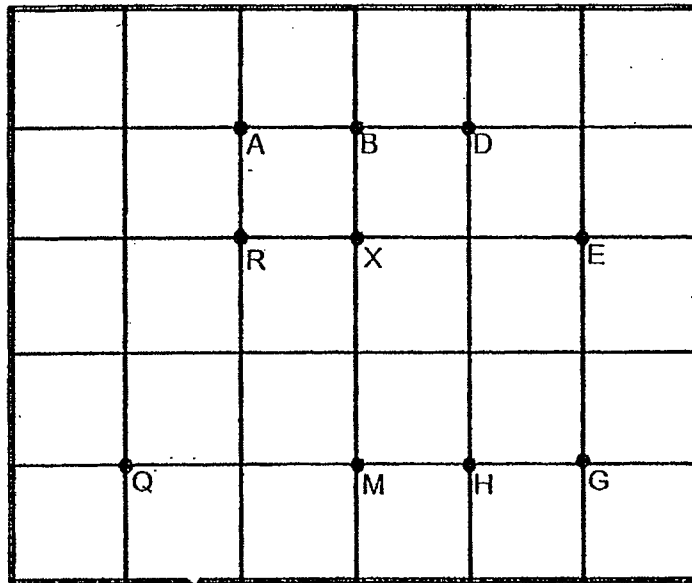

- (a) (i) Point X is west of Point \_\_\_\_\_ .  
(ii) Point X is north-east of Point \_\_\_\_\_ .
- (b) Sally was standing at Point X and she was facing Point D.  
She then turned in an anti-clockwise direction until she was facing Point G.  
How many complete right angles did she turn?
- (c) REGQ and REGM are trapeziums with a pair of parallel sides.  
Name 1 other such trapezium with RB as one of the parallel sides.

Ans: (a) (i) \_\_\_\_\_

(ii) \_\_\_\_\_ [1]

(b) \_\_\_\_\_ [1]

(c) Trapezium \_\_\_\_\_ [1]

8. Jasmine and Kaixin started cycling at the same time along a 5.2 km track. Both of them did not change their speeds from start to finish. Jasmine cycled at 400 m/min. When she reached the end of the track, Kaixin was 780 m behind her. What was Kaixin's cycling speed in m/min?

Ans: \_\_\_\_\_ [3]

9. In the figures below, Tank A and Tank B are partially filled with water. All the water from both Tank A and Tank B is poured into Tank C. What is the height of water in Tank C?

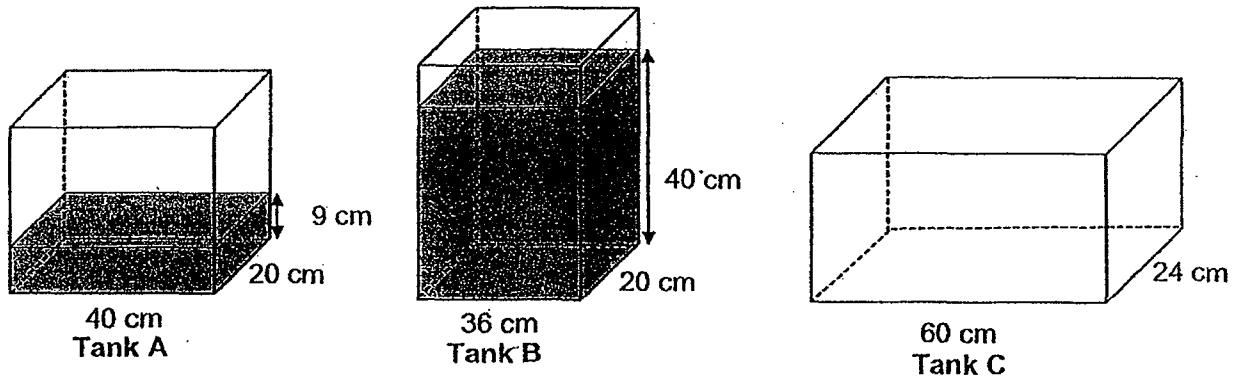

Ans: \_\_\_\_\_ [ 4 ]

14

10. Two groups of pupils sold handicrafts for charity. Card holders are sold at \$15 each and photo frames are sold at \$8 each. The table below shows the items sold by Group A.

Item	Number of items sold	Cost per item
Card holders	9	\$15
Photo frames	12	\$8

- (a) What was the total amount of money collected by Group A?
- (b) Group B sold as many handicrafts as Group A but collected an additional amount that is more than \$50.  
What could possibly be the number of card holders and photo frames sold by Group B?

Ans: (a) \_\_\_\_\_ [ 2 ]

(b) Card holders: \_\_\_\_\_

Photo frames: \_\_\_\_\_ [ 2 ]

11. Three boxes, A, B and C, contain some marbles. Box C contains 272 marbles.

Box A contains  $\frac{3}{4}$  of the total number of marbles in Boxes B and C. The ratio of the number of marbles in Box B to the number of marbles in Box C is 1 : 2.

How many marbles are there altogether in Boxes A and B?

Ans: \_\_\_\_\_ [3]

12. Last year, the ratio of the number of men to the number of women who signed up for a marathon was 5 : 4. This year, the number of men increased by 30% and the number of women decreased by 50%. A total of 4675 men and women signed up for the marathon this year. What is the difference between the total number of people who signed up for the marathon in the two years?

Ans: \_\_\_\_\_ [ 3 ]



13. Ali, Banu, Caixuan and Dave shared a bag of beads.

Ali had  $\frac{1}{2}$  as many beads as Banu.

The total number of beads Ali and Banu had was  $\frac{3}{5}$  the number of beads Caixuan had.

Dave had  $\frac{2}{5}$  the total number of beads the four children had.

Dave had 52 beads more than Ali.

- (a) What fraction of the beads did Banu have?
- (b) How many beads did the children have altogether?

Ans: (a) \_\_\_\_\_ [ 2 ]

(b) \_\_\_\_\_ [ 2 ]

14. A unit shape in the form of a quadrilateral is drawn in the dot paper below.  
It has an area of  $2x$  units<sup>2</sup>.

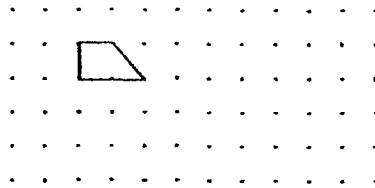

A quadrilateral with 2 lines of symmetry is formed when 2 such unit shapes are joined together as shown below.

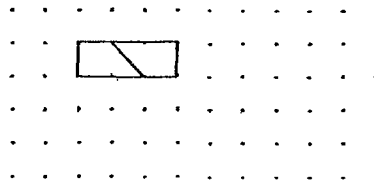

Using the smallest number of unit shapes,

- (a) (i) form a square. [ 1 ]  
(ii) find the area of the square in terms of  $x$ .

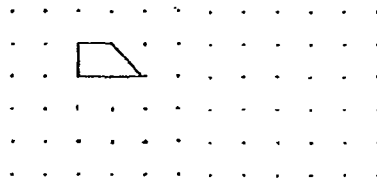

- (b) (i) form a quadrilateral that has only one line of symmetry. [ 1 ]  
(ii) name the type of quadrilateral formed.

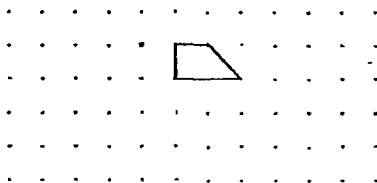

Ans: (a)(ii) \_\_\_\_\_ [ 1 ]

(b)(ii) \_\_\_\_\_ [ 1 ]

15. Sharon receives \$50 from her father each month as pocket money. She spends some money and saves the rest. The line graph below shows the amount of pocket money she saved over a period of 5 months.

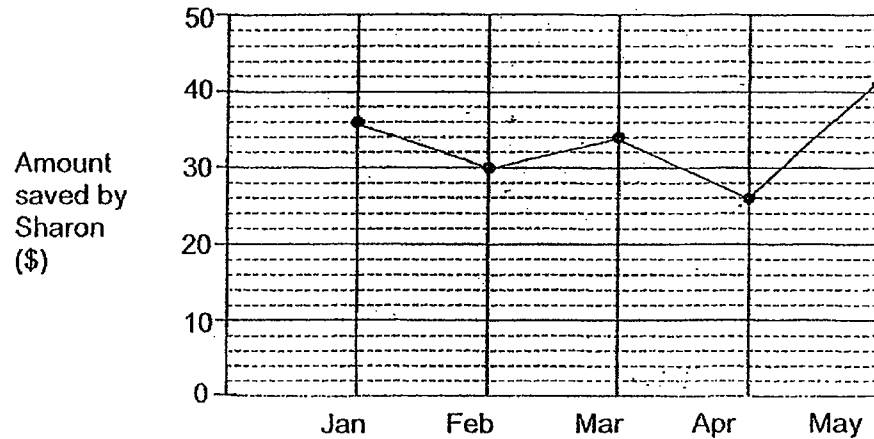

- (a) What is her total savings from January to May?  
(b) In which month did she spend the most?  
(c) Sharon wants to buy a bicycle which costs \$230. How many more months does she need to save after May so that she can buy the bicycle as soon as possible?

Ans: (a) \_\_\_\_\_ [1]

(b) \_\_\_\_\_ [1]

(c) \_\_\_\_\_ [2]

16. The figure below is formed by 2 quadrants and a rectangle overlapping one another.  
 The radius of the smaller quadrant is 10 cm.  
 Find the area of the shaded part of the figure.

Take  $\pi = 3.14$

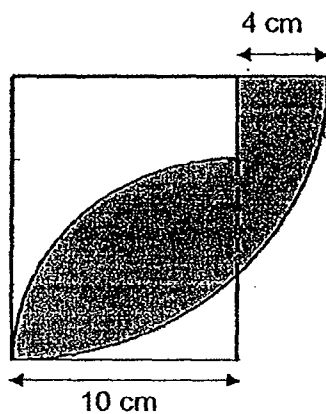

Ans: \_\_\_\_\_ [ 5 ]

17. A man bought  $\frac{3}{5}$  as many cartons of mangoes as papayas.

He paid \$540 for the mangoes and papayas.

The total cost of the mangoes was twice that of the papayas.

Each carton of mangoes cost \$28 more than each carton of papayas.

(a) How much did he pay for the mangoes?

(b) How many cartons of papayas did he buy?

Ans: (a) \_\_\_\_\_ [ 2 ]

(b) \_\_\_\_\_ [ 3 ]

*Remember to check your work!*  
*~ End of Paper ~*

/ 5



SCHOOL : MAHA BODHI PRIMARY SCHOOL  
 LEVEL : PRIMARY 6  
 SUBJECT : MATH  
 TERM : 2019 PRELIM

**PAPER 1 BOOKLET A**

Q 1	Q2	Q3	Q4	Q5	Q6	Q7	Q8	Q9	Q10
4	3	2	2	2	3	3	3	3	2

Q 11	Q12	Q13	Q14	Q15
4	1	3	4	2

**PAPER 1 BOOKLET B**

Q16)	1700
Q17)	$6 \times 3 = 18$ $\frac{1}{2} \times 18 = 9$ $\frac{9}{30} = \frac{3}{10}$
Q18)	$5 \times 5 = 25$ $300 \div 25 = 12$
Q19)	$2.4 \times 5 = 12$ $12 - 10.8 = 1.2$
Q20)	$3y + 3y + 3 = (6y + 3)$
Q21)	$\frac{1}{2} \div 4 = \frac{1}{2} \times \frac{1}{4} = \frac{1}{8}$ $\frac{1}{8} = \frac{125}{1000} = 0.125$ $= 0.125 \times 3 = 0.375$ $= 0.5 + 0.375 = 0.875$
Q22)	$12 - 4 = 8$ $\frac{1}{2} \times 8 \times 6 = 24cm^2$

Q23)

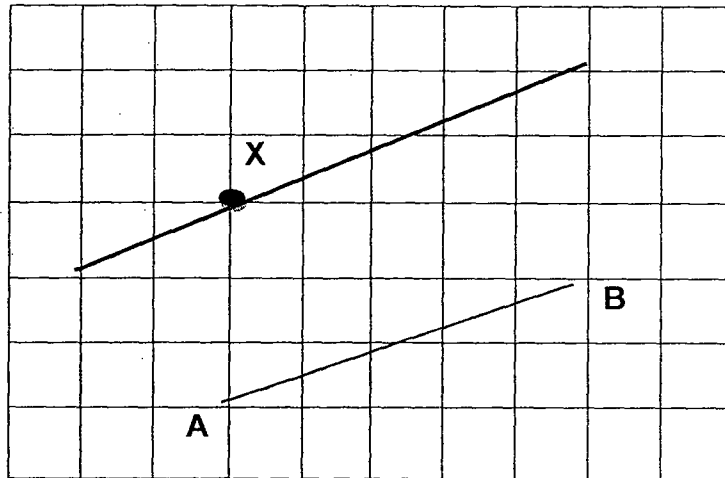

Q24)

Multiple of 4 : 4,8,12      Multiple of 6 : 6,12  
 $3 \times 5 = 15$   
 $2 \times 8 = 16$   
 $15 + 16 = \$31$

Q25)

			√
		√	

Q26)

$5 - 1 = 4$   
 $66 - 26 = 40$   
 4 units = 40  
 1 unit =  $40 \div 4 = 10$   
 $10 + 66 = 76$  stamps

Q27)

$\angle XVZ = 180^\circ - 130^\circ = 50^\circ$   
 $\angle XVZ = \angle YXV = 50^\circ$   
 $\angle XYV = 180^\circ - 50^\circ \times 2 = 80^\circ$   
 $\angle ZYX = 180^\circ - 80^\circ = 100^\circ$   
 $\angle ZYX = \angle ZWX = 100^\circ$

Q28)

$\frac{1}{2} \times 100\% = 50\%$   
 $50\% - 15\% - 30\% = 5\%$   
 $= \frac{5}{100} = \frac{1}{20}$

Q29)

$\frac{2n+16-13}{3} = \left(\frac{2n+3}{3}\right)m$



Q30)	$6 \times 3 \times 3 = 54$ $54 - 13 = 41$
------	--

**PAPER 2**

Q1)	$7 + 13 + 6 = 26$ $40 - 26 = 14$										
	<table border="1"> <caption>Data from Bar Chart</caption> <thead> <tr> <th>Food Item</th> <th>Number of Pupils</th> </tr> </thead> <tbody> <tr> <td>Lontong</td> <td>7</td> </tr> <tr> <td>Nasi Lemak</td> <td>13</td> </tr> <tr> <td>Mee Siam</td> <td>14</td> </tr> <tr> <td>Mee Soto</td> <td>6</td> </tr> </tbody> </table>	Food Item	Number of Pupils	Lontong	7	Nasi Lemak	13	Mee Siam	14	Mee Soto	6
Food Item	Number of Pupils										
Lontong	7										
Nasi Lemak	13										
Mee Siam	14										
Mee Soto	6										
Q2)	$101 - 1 = 100$ $100 \times 4 = 400$ $6 + 400 = 406$ lines										
Q3)	$4x \times 2 = 8x$ $8x - 5 + 8x + 4x = (20x - 5)$ kg										
Q4)	$14 \div 2 = 7$ $\frac{22}{7} \times 7 \times 7 \times \frac{1}{4} = 38.5$ $7 \times 7 = 49$ $49 - 38.5 = 10.5$ $10.5 \times 4 = 42\text{cm}^2$										
Q5)	$8 - 1 = 7$ $12.11 \div 7 = 1.73$ $15 - 1 = 14$ $1.73 \times 14 = 24.22\text{m}$										
Q6)	a) $\angle QRS = \angle QPS = 66^\circ$ b) $\angle PQS = \angle PSQ$										

	$= \frac{180^\circ - 66^\circ}{2} = 57^\circ$
Q7)	<p>a i)E ii)Q b)3 c)Trapezium RBEM</p>
Q8)	<p><math>5200m \div 400m/min = 13min</math>  <math>5200m - 780m = 4420m</math>  <math>4420m \div 13min = 340m/min</math></p>
Q9)	<p><math>40 \times 20 \times 9 = 2700</math>  <math>36 \times 20 \times 40 = 28800</math>  <math>28800 + 7200 = 36000</math>  <math>36000 \div 60 \div 24 = 25 \text{ cm}</math></p>
Q10)	<p>a) <math>9 \times 15 = 135</math>  <math>12 \times 8 = 96</math>  <math>96 + 135 = 231</math></p> <p>b) Multiple of 7 : 7,14,21,28,35,42,49,56  <math>15 - 8 = 7</math>  <math>56 \div 7 = 8</math>  <math>8 + 9 = 17</math> card holders  <math>12 + 9 = 21</math>  <math>21 - 17 = 4</math> photo frames</p>
Q11)	<p>8 units = 272  1 unit = <math>272 \div 8 = 34</math>  9 units = <math>34 \times 9 = 306</math>  4 units = <math>34 \times 4 = 136</math>  <math>136 + 306 = 442</math></p>
Q12)	<p>17 units = 4675  18 units = <math>\frac{4675}{17} \times 18 = 4950</math>  <math>4950 - 4675 = 275</math></p>

Q13)

a) A : B

$$1 : 2 \rightarrow 3 \rightarrow \frac{3}{5}$$

$$1 \rightarrow \frac{1}{5}$$

A : B : C

$$1 : 2 : 5 \rightarrow 8 \rightarrow \frac{3}{5}$$

17 : B : C : D

$$1 : 2 : 5 : \frac{8}{3} \times 2$$

$$(1 : 2 : 5 : \frac{16}{3}) \times 3$$

$$3 : 6 : 15 : 16$$

$$\frac{6}{3+6+15+16} = \frac{6}{40}$$

b) A : B

$$1 : 2 \times 3$$

$$3 : 6$$

A : B : C

$$3 : 5 \times 3$$

$$9 : 15$$

Dave : All 4

$$2 : 5 \times 8$$

$$16 : 40$$

13 units = 52

$$40 \text{ units} = \frac{52}{13} \times 40 = 160$$

Q14)

a i)

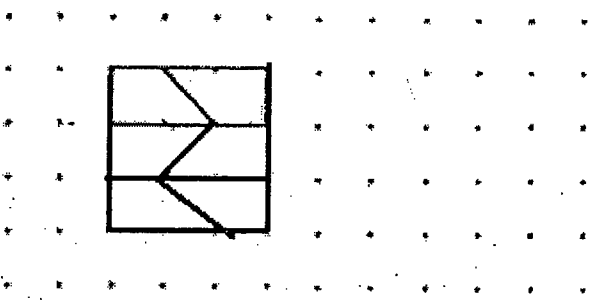

$$\text{ii) } 2x \times 6 = 12x \text{ units}^2$$

b i)

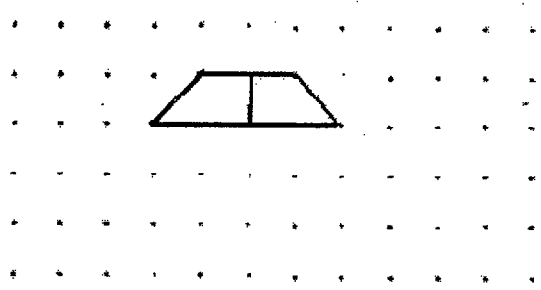

ii) Trapezium

Q15)	<p>a) <math>36 + 30 + 34 + 26 + 42 = 168</math>  b) April  c) <math>230 - 168 = \\$62</math>    2 more month</p>
Q16)	<p><math>10 + 4 = 14</math>  <math>14 \times 10 = 140</math>  <math>3.14 \times 10 \times 10 \times \frac{1}{4} = 78.5</math>  <math>140 - 78.5 = 61.5</math>  <math>3.14 \times 14 \times 14 \times \frac{1}{4} = 153.86</math>  <math>153.86 - 61.5 = 92.36\text{cm}^2</math></p>
Q17)	<p>a) <math>540 \div 3 = 180</math>  <math>180 \times 2 = \\$360</math>  b) <math>180 \div 5 = 36</math>  <math>360 \div 3 = 120</math>  <math>120 - 36 = 84</math>  <math>84 \div 28 = 3</math>  <math>3 \times 5 = 15</math></p>